

SOLARHOT™

Glycol Solar Thermal System

Installation/ Owner's Manual



Description / Applications

System Overview

The SOLARHOT™ solar thermal glycol system can provide 70-90% of your domestic hot water needs annually. A water/glycol mixture running through a solar collector is heated by the sun. The heat is then transferred to the potable water in your hot water tank. Water is circulated through each “loop” by a high efficiency circulation pump through a brazed plate heat exchanger. The heat transfer fluid has a very low freezing point which keeps your collectors safe from freeze damage.

The pumps are controlled by a differential control which reads the temperatures at the collector and in the tank. It provides power to the pumps when the temperature in the collectors is 16° higher than the tank water. The control includes a digital display with touch pad to easily program temperature limits, differentials, vacation modes, and other advanced options.



Contents

Features	3
SolarHot Glycol Advantage	3
Safety	3
Certification	3
Materials List	4
GS2P Glycol System.....	4
GS2P3RM Glycol System with Adjustable Mount Hardware	4
Additional Materials Required	5
Glycol System Specifications	5
Installation	6
Collector Orientation	7
Installing the Collectors	8
Installing the Mounting Brackets	8
Preparing the Collectors.....	9
Mounting the Collectors	10
Connect to Pipes.....	13
Installing the Temperature Sensor	14
Pipe Runs.....	14
Installing the Tempering Valve.....	14
Mounting the SolVelox on the Storage Tank	15
Installing the Differential Control	16
Check Collector Loop for Leaks	18
Charging the System.....	18
Starting the System.....	19
Check System Operation	19
Operation	19
Vacation Settings	19
Emergency Shut Off.....	20
Maintenance.....	20
Freeze Protection.....	20
Clear Sediment from Strainer.....	20
Descaling the Heat Exchanger	20
Change Heat Transfer Fluid	21
Pumps	21
Service	21
Warranty Information	22

**WARNING****Electrical Shock, Fire, Explosion and Burn Hazards**

This system must be installed, adjusted, and put into operation only by a trained, qualified professional or service agency in accordance with the National Electric Code ANSI/NFPA 70 (Canada CSA C22.1), state and local codes, and authorities having jurisdiction.

The installer must carefully read and follow the installation and service instructions contained in this manual. Make them available to the equipment owner, so they can be kept for future reference.

Features

SOLARHOT Glycol Advantage

SOLARHOT has uniquely created the SolVelox package, which pre-assembles and integrates an oversized stainless steel heat exchanger along with the pumps and valves necessary to drive a two-loop solar system. The heat exchanger and pumps are sized to meet the heat output of up to six solar collectors, so one SolVelox appliance provides an economical solution as you scale the system to meet your particular needs. Also, the Solvelox is externally mounted in order to reduce maintenance issues.

Safety

The best performance will come from a solar collector with aluminum sides and low iron solar glass well sealed to hold the heat. These materials weigh 80-150 lbs., depending on the size of the collector.

**WARNING****Electrical Shock and Fall Injury Hazard.**

Use extreme caution when mounting collectors on a roof or when connecting any wiring or electrical hookups.

- ALWAYS use fall protection
- Secure all ladders on level ground
- Locate all possible hazards, overhead wires, loose shingles etc
- Make sure power is turned off before adding water to the system
- NEVER connect power to the water heater or storage tank until it has been filled.
- Use a tempering valve or mixing valve to prevent scalding
- Consult proper authorities and check with your local building inspector for permit requirements and local building codes before project commencement. System must meet local code requirements for penetrating structural members and fire-rate assemblies.

Certification

The solar energy system described by this manual, when properly installed and maintained, meets the minimum standards established by the SRCC. This certification does not imply endorsement or warranty of this product by the SRCC.

Materials List

GS_P or GS_S Glycol System

System requirements:

- SOLARHOT Platinum or Silver solar collectors (Platinum include 1" gasketed unions)
- (1) SOLARHOT SolVelox glycol pump package (pumps, heat exchanger with Elastomeric insulation, Steca differential control), including mounting bracket, six (6) screws, two (2) sensors (third sensor optional), strain reliefs for sensors, and 50 ft. sensor wire
- (1) minimum 2 gal. expansion tank, (flex line and mounting bracket optional)
- (2) Flush mount hardware
- (1) Solar Dip tube
- (1) ASSE 1017 certified mixing / anti-scald valve
- (1) Roof kit per collector array (flashing, caps, plug, reducing elbows)
 - (1) 1/2" copper roof flashing with special adapter cap
 - (1) 1/2" copper roof flashing with gooseneck
 - (1) Row Kit (for Platinum collectors, Silver collectors add (2) gasketed unions per collector or copper couplings and caps)
 - (2) 1"x1/2" elbows

GS_P_RM or GS_S_RM Glycol System with Adjustable Mount Hardware

System requirements:

- SOLARHOT Platinum or Silver solar collectors (Platinum include 1" gasketed unions)
- (1) SOLARHOT SolVelox glycol pump package (pumps, heat exchanger with Elastomeric insulation, Steca differential control), including mounting bracket, six (6) screws, two (2) sensors (third sensor optional), strain reliefs for sensors, and 50 ft. sensor wire
- (1) 2 gal. expansion tank, (flexible line and mounting bracket optional)
- (2) Adjustable mount hardware (telescoping legs to vary mounting angle)
- (1) Solar Dip tube
- (1) ASSE 1017 certified mixing/ anti-scald valve
- (1) Roof kit per collector array (flashing, caps, plug, reducing elbows)
 - (1) 1/2" copper roof flashing with special adapter cap
 - (1) 1/2" copper roof flashing with gooseneck
 - (1) Row Kit (for Platinum collectors, Silver collectors add (2) gasketed unions per collector or copper couplings and caps)
 - (2) 1"x1/2" elbows

Additional Materials Required

- Electric water heater to use for solar storage tank, 80 gal. minimum
- 1/2" copper tubing
- Mounting hardware
- 1" elastomeric insulation (e.g. Nomaco K-Flex LS)
- PVC insulation jacketing (e.g. Speedline Smoke Free PVC)
- Vinyl tape
- 40% GRAS propylene glycol heat transfer solution
- Drip pan (optional, see Installation Diagram)

Glycol System Specifications

GS2P and GS2P3RM

Congratulations on the installation of your SOLARHOT System! Correctly installed and maintained, your system should provide you with many years of uninterrupted solar hot water. The solar collectors are designed to last 25-35 years, electric water heaters 10-20 years, and pumps, controls, and valves 5-10 years. Local water quality and usage will greatly affect life expectancies.

Solar Collector: (Recommended)

SOLARHOT Platinum or Silver flatplate collectors

Solar Storage Tank (80 gal. minimum), not included:

Whirlpool EE3Z80HD055V

American Premier E62-80H-045DV

Rheem 81VR80TC-1

Lochinvar FTA082K

Pumps:

Collector Loop Glycol: Wilo Star 16 Tank Loop: Wilo Star 8B

Controller:

Differential Control TR 0301U, includes two (2) (third sensor optional) PT1000 sensors, one is prewired

Heat Exchanger:

SolarHot P-HX-210512

System operating parameters:

Pressure on a glycol system should be between 25-30 psi

Flow meter should read about 5 gpm on the collector loop and 3.5 on the tank loop

Installation

Refer to **Figure 1** for the relative location of the pipes, collectors, and SolVeloX pump package. The cold water supply line to the solar storage tank must be covered with a minimum of 7/8" x 1/2" insulation for 5 feet from the water heater. Please note that if the water storage tanks are located in or above living spaces, a drip pan with a drain line to the outside of the building is required.

Figure 1 - Installation Diagram

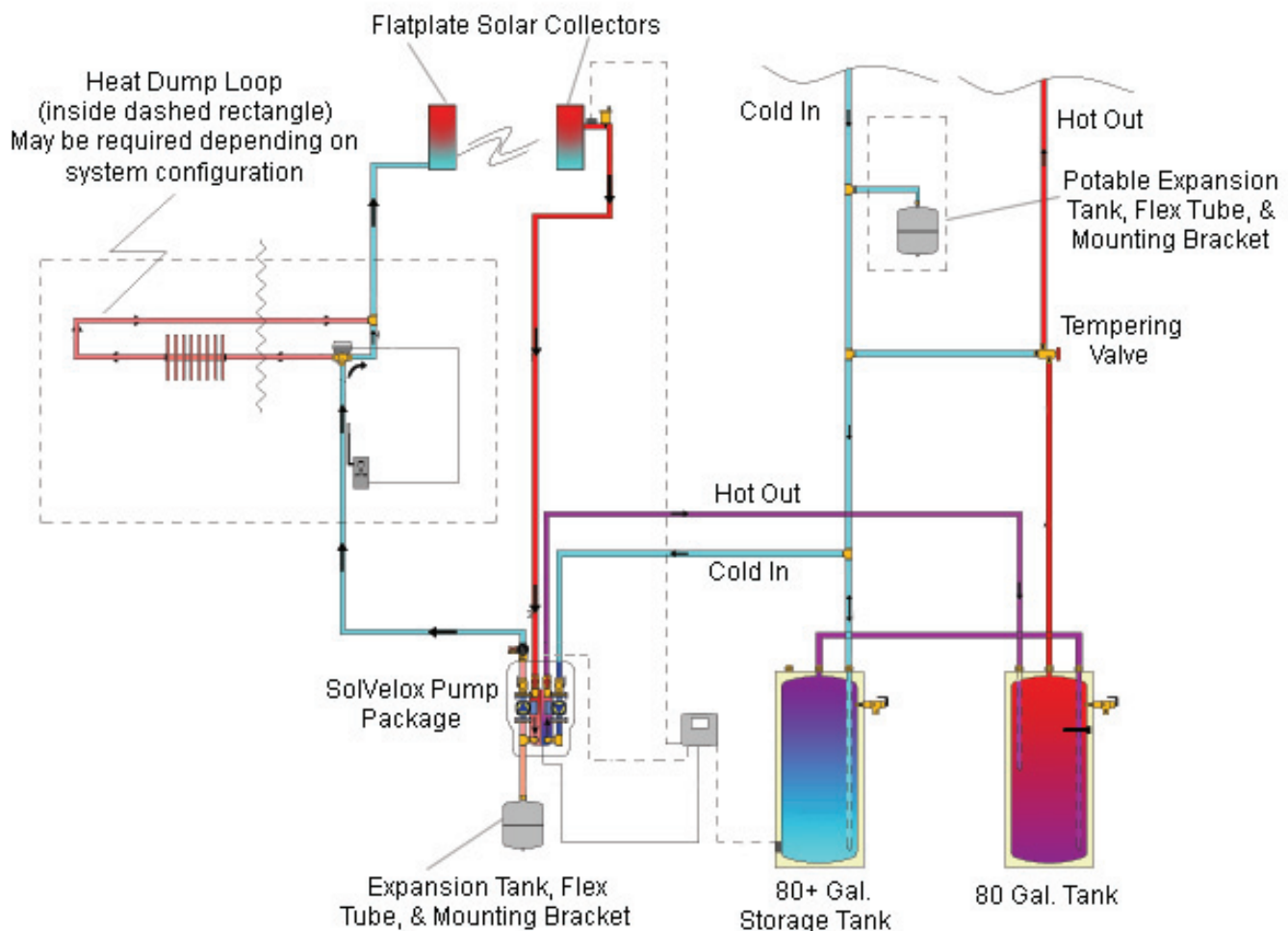

SK0045

Notes:

- The pipe, heat exchanger, expansion tank, and pump size will be determined by the size of the collector array.
- All pipes 1/2" diameter minimum.
- An expansion tank should be installed on the potable water side for systems that do not allow backflow.
- Refer to manufacturer's instructions regarding installation of the tempering valve.

There are two basic methods for mounting collectors on the roof or ground, as outlined in **Figure 2**.

1. **Flush Mount**– This is the most common method. If the existing roof line is not suitable for any reason, the adjustable mount may be employed.
2. **Adjustable Mount**– This is sometimes required on a flat roof or in the case of a ground mount to optimize available solar energy.

Figure 2 - Mounting Options

Flush Mount:



Adjustable Mount:



Collector Orientation

The collectors should be mounted as close to due south as is reasonable, considering the roof line. However, if the collector is mounted within 45 degrees of south any performance drop is insignificant. The aesthetics of flush mounting a collector on the roof will generally outweigh performance improvements less than 5%.

The collectors should ideally be inclined at the same angle as the latitude, i.e. if you are located in Raleigh, NC (latitude 38 degrees) you would ideally have the collectors inclined 38° from horizontal. Testing has shown that mounting a collector within $\pm 15^\circ$ of the site's latitude will lead to no significant degradation in the collector's annual performance.

Pay close attention to the angle and direction of the roof line. If your roof line doesn't match the ideal criteria listed above, we recommend adding collector area as opposed to mounting the collector at a tilt. For example: If your roof faces the southeast, you may use three collectors instead of the two collectors which would be typical for a family of four.

Further, minimize the shade over the collectors. Collectors should receive 6-8 hours of direct sunlight each day for optimal performance.

Installing the Collectors

WARNING Fall Injury Hazard.

Prepare the roof to work safely, employing roof scaffolding methods approved by OSHA.

Unfortunately there are no stud finders for rooftops, but it is important to mount the collectors into the rafters. Here are a couple of ideas for how to locate a rafter:

- From inside the attic, drill an angled hole from the intersection of the roof deck and the rafter at a 45° angle into the roof deck from the intersection. The spot where the drill first penetrates the roof should be approximately the center of the rafter.
- From the attic, measure the distance from an existing roof protrusion to the nearest rafter. Use that same measurement on the outside of the roof.
- Drill from the outside of the roof. Measure from the attic side of the hole to the nearest rafter. Use the same dimensions of the outside.
- Using a 3/16" x 12" long drill bit, drill from the inside of the house through the rafter to the outside.

Installing the Mounting Brackets

1. Mark a 10' long horizontal line at least 18" below the peak of the roof.
2. Measure 97½" down from the first horizontal line and mark another 10' line as shown in **Figure 3**.

Figure 3 - Spacing

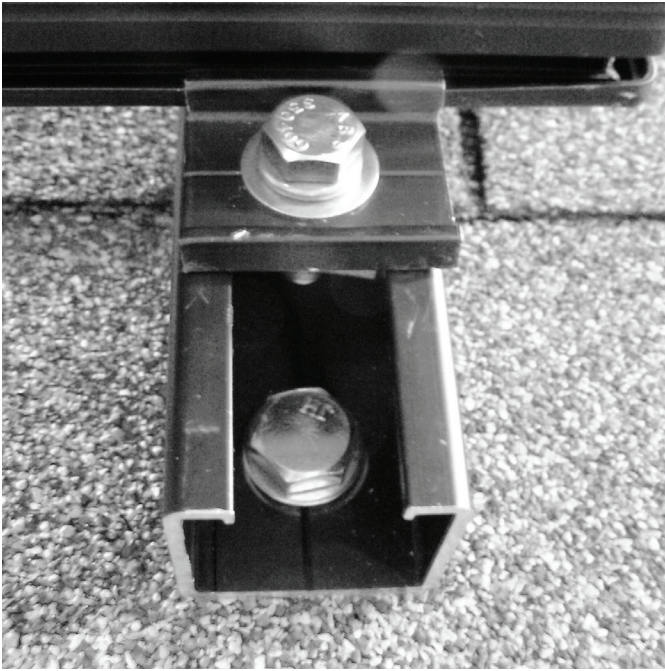

3. Locate the center of a rafter and mark vertically along the rafter with a chalk line between the two horizontal lines.
4. Using the rafter spacing, make vertical marks over the center of the rafters, marking all the rafters that the collectors will span.
5. Using the mounting foot as a template, hold the mounting foot at the center of each intersection. Holding the foot at the intersection of the chalk lines, mark the holes with a marker. Repeat this procedure until each of the mounting foot locations have been marked. (four mounting feet for each collector)
6. With a 3/16" bit, drill a pilot hole at each one of the marks you just made.
7. Place the mounting feet over the pilot holes. Screw the brackets to the rafters using 3/8" x 2 1/2" stainless steel lag screws, flat washers, and lock washers as in **Figure 4a or 4b**.

Figure 4a - Flat Mount Shown**Figure 4b - Adjustable Mount Shown****Preparing the Collectors**

⚠ WARNING Burn hazard.

When working with the solar collectors, cover the panels until installation is complete. Both the panels and unions quickly begin to collect heat and pose a burn hazard.

The end of the collectors with the SOLARHOT name plate should be installed closest to the ridge of the roof, as there are weep holes to release condensation on the other end. The corners of the collectors will have 1" unions preinstalled. These will be mounted with elbows as in **Figure 5a**. Depending on system flow configuration, the two ends not in use will have end caps as in **Figure 5b**.

Figure 5a - Collector Configuration**Figure 5b - Collector Configuration**

Figure 6 - Collector Flow

Right to Left Flow
Collectors slope down 1/4" per foot toward cold water supply.

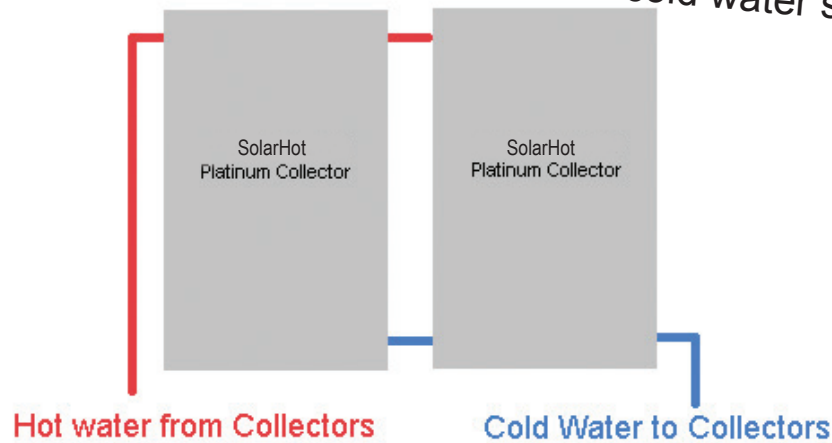

Left to Right Flow
Collectors slope down 1/4" per foot toward cold water supply.

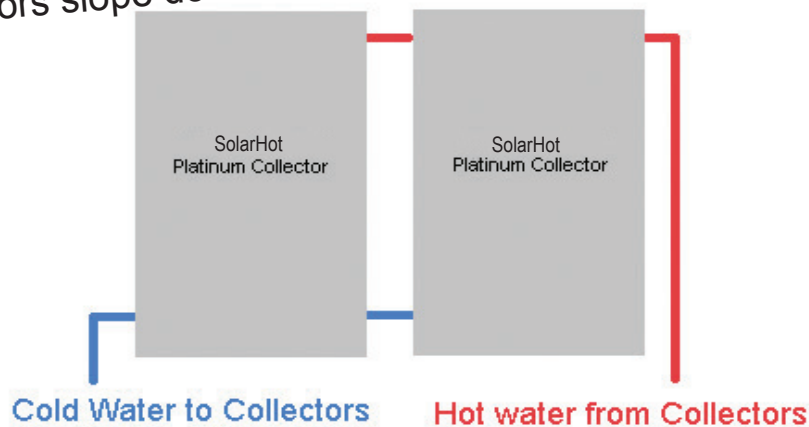

Mounting the Collectors

Mount the collectors so that there is a 1/4" drop per foot towards the inlet as in **Figure 6**. This facilitates draining of the system should it be required.

Refer to Figure 7 for proper installation.

1. The mounting clip is made up of two parts joined by a stainless steel bolt with lock washer as in **Figure 8a and b**. Before taking the collectors up to the roof, slide the stainless steel sliding nut into the anodized aluminum channel foot. Now carefully place the first collector so that the mounting clip fits in the mounting groove that runs around the bottom edge of the collector and tighten the bolt. Ensure that the clips are installed securely.

Figure 7a: Flush Mount

- Notes:
 1. Four feet per collector, as shown.
 2. Feet are to be located above framing beam or rafter.

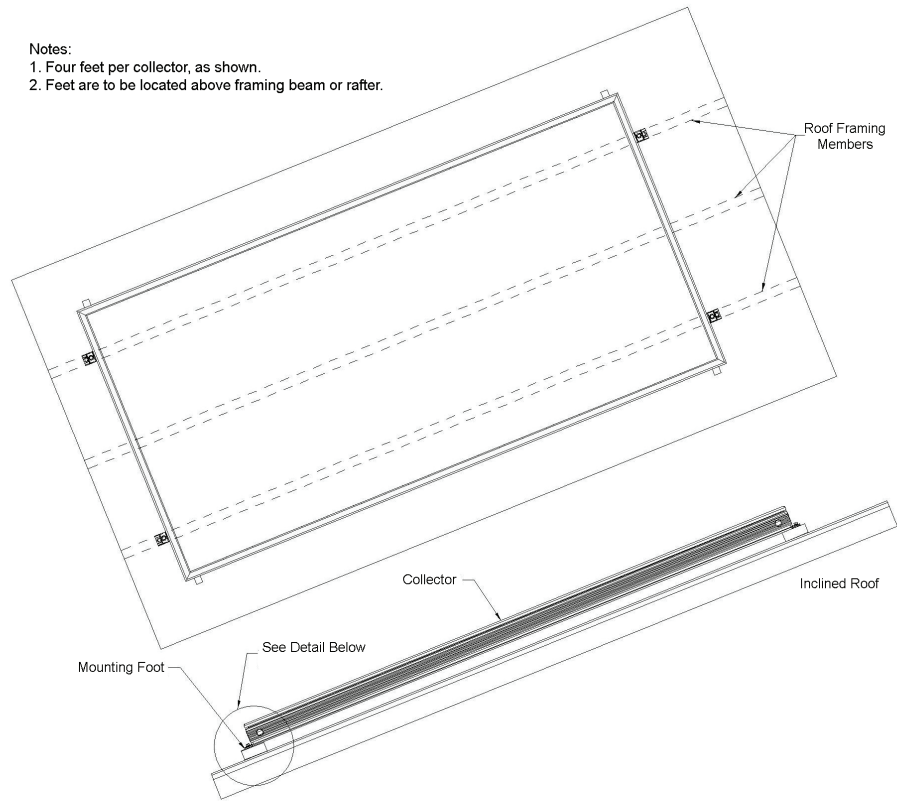

Mounting Detail

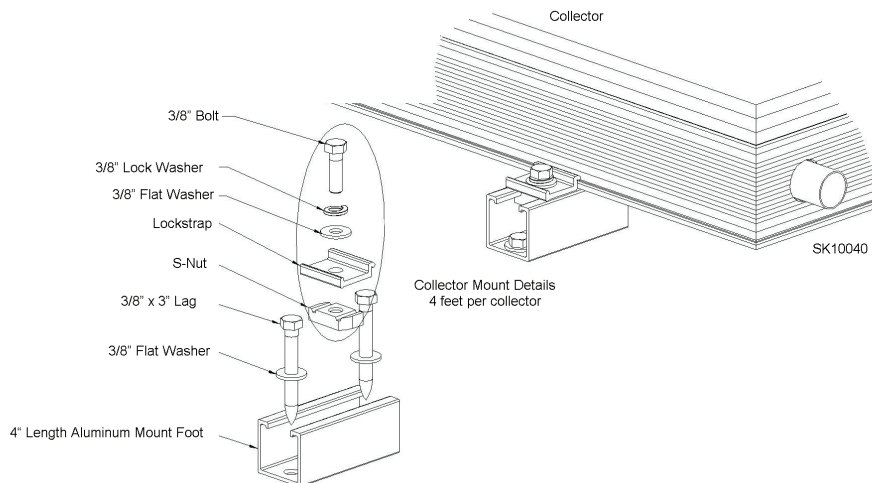
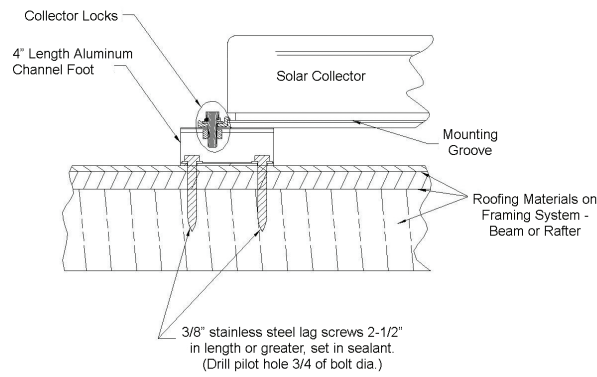

Figure 7b: Adjustable Mount

- Notes:
 1. Four feet per collector, as shown.
 2. Feet are to be located above framing beam or rafter.

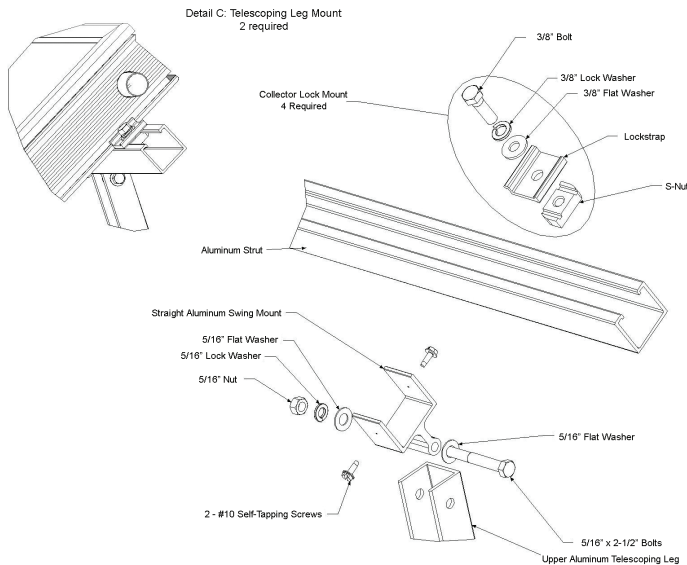
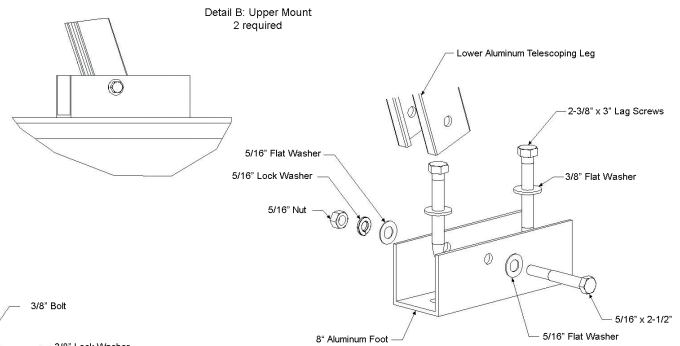
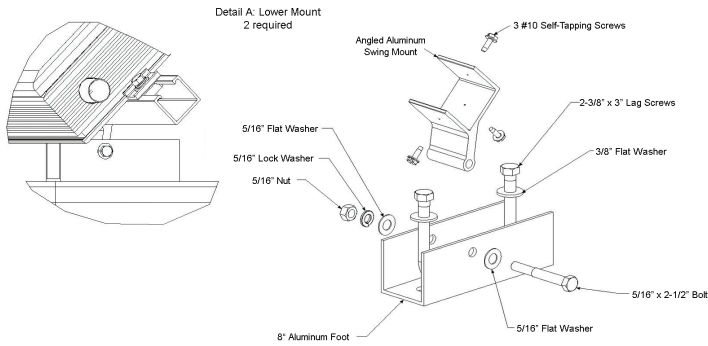
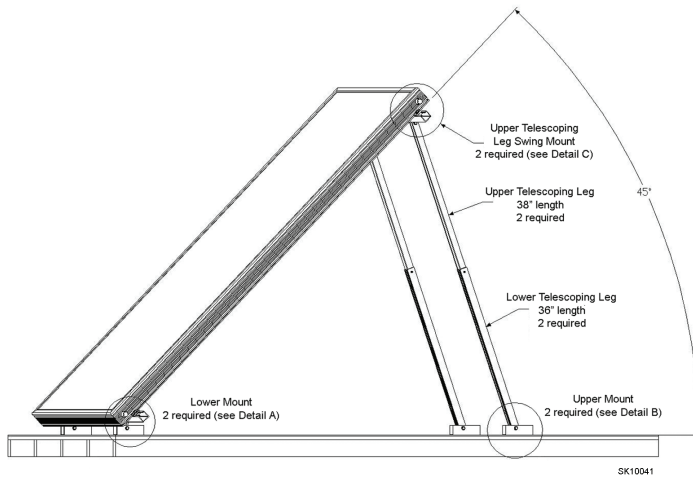

Figure 8a: Mounting Clips for Flush Mount

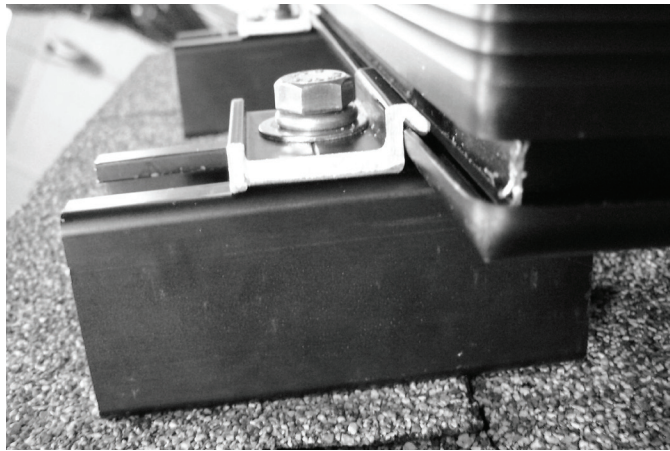
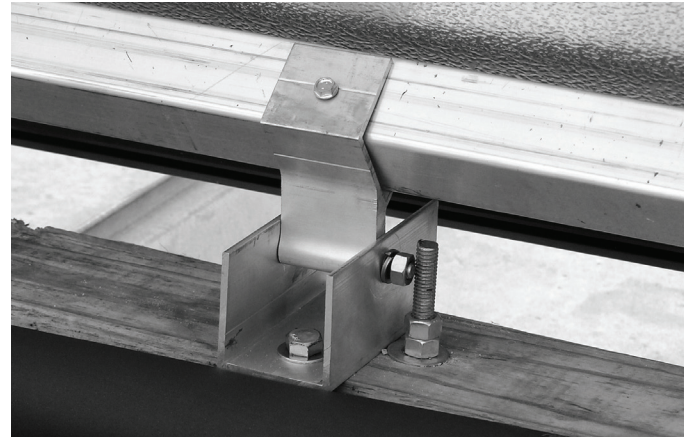
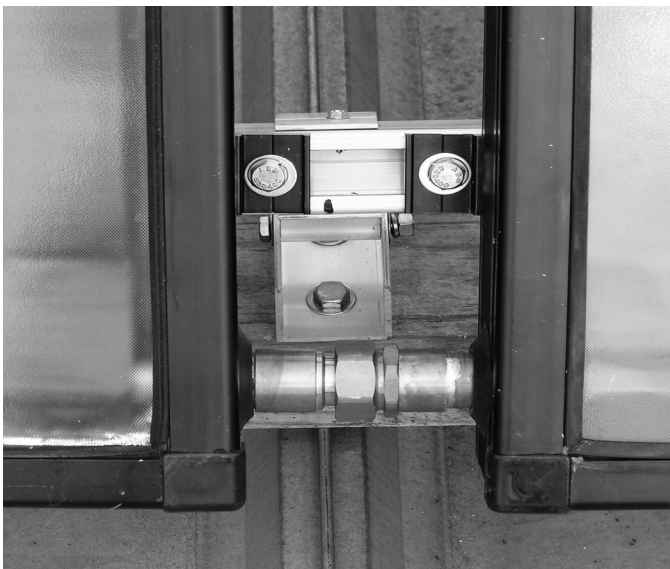

Figure 8b: Mounting Clips for Adjustable Mount



2. Mount the next collector so that the unions join to the first collector and secure the mounting clips as in **Figure 9**.

Figure 9: Joining Collectors



Connect to Pipes

1. Using a wood bit the same size as your pipes, drill a hole in the center of a shingle below where the bottom corner of the collector inlet will be and in the opposite corner, where the collector outlet will be.
2. Apply sealant to the underside of the copper flashing. Carefully raise the drilled shingle, place flashing underneath and insert collar through the hole as shown in **Figure 10**.
3. Run pipes from attic through the copper flashing and sweat connect them to the street elbows. **See "Pipe Runs" section for specific instructions.**

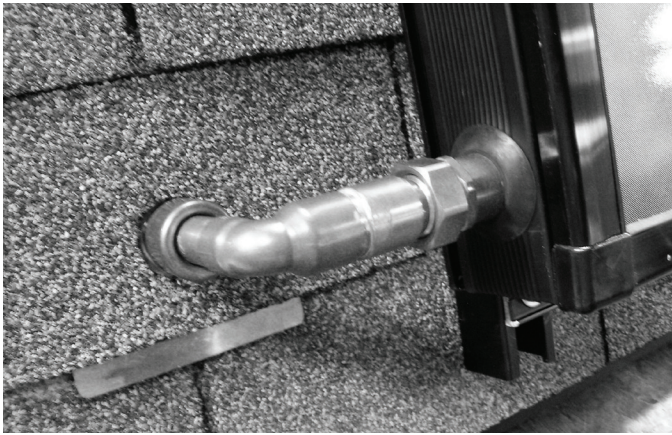
Figure 10 - Copper Flashing**Installing the Temperature Sensor**

1. Strap the PT1000 probe sensor to the copper pipe at the collector outlet using a stainless steel screw clamp as shown in **Figure 11a**.
2. Feed the sensor wire through the gooseneck of the copper flashing as in **Figure 11b**. The flashing can then be soldered to seal it from leaks.
3. For sensor to operate correctly it must be isolated from exterior conditions. All of the exposed copper, as well as the sensor itself, needs to be **completely covered** with insulation and UV jacketing.

Pipe Runs

NOTICE If the water storage tanks are located in or above living spaces, a drip pan with a drain line to the outside of the building is required.

Use 1/2" copper tubing or larger. All pipes should be wrapped with at least 3/4" thick insulation. We recommend 1" Elastomeric insulation. Outdoor pipes should also be jacketed with UV protection material or some other means to protect it from moisture and ultraviolet deterioration. We recommend Nomaco K-Flex LS with Speedline Smoke Safe

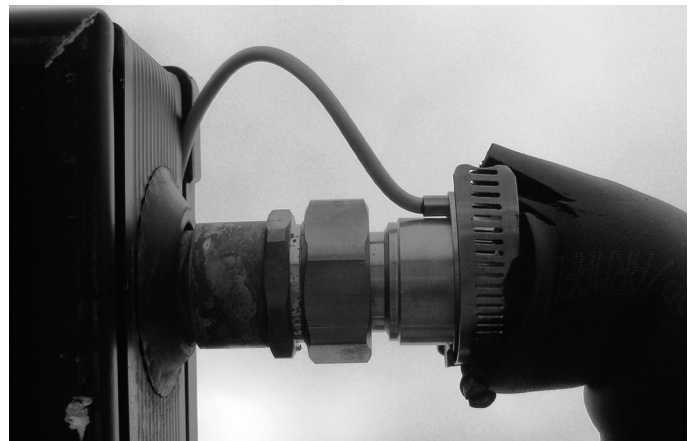
Figure 11a - Sensor Installation**Figure 11b - Sensor Installation**

PVC Fitting Covers and vinyl tape.

All pipes must be well supported or they will sag. Sagging pipes may trap water. Hanger should spread the load so that the insulation is not compressed. Place supports every 4.7 feet.

Installing the Tempering Valve

Refer to manufacturer's instructions for information on installing the tempering valve.

⚠ WARNING Burn and Scald Hazard.

Be sure to install the Watts 1170-M2 hot water temperature valve to control water temperature at a safe operating level. Carefully follow the manufacturer's procedures for installation to ensure accurate water temperature sensing and effective control operation.

Mounting the SolVelox on the Storage Tank

1. Confirm that the P&T valve is on the side of the tank. If it is on the top of the tank, unscrew it and place it in the port on the side of the tank if a side port is available.
2. Use needle nose pliers to remove the heat trap from the hot side of the tank and set aside.
3. Feed the solar dip tube into the tank, closed end down into the port previously noted as the “hot” port until it seats.
4. Lay the tank down on the ground on top of cardboard or towels.
5. Place the bracket over the SolVelox and place the assembly on the side of the tank. The side of the SolVelox should be 1” to the left of the top electrode cover. The bracket should lie flat on the top of the tank. Scribe the tank to match the bracket location.
6. Using two #10 - 16 x 3/4” self drilling screws, screw the top of the bracket to the top of the hot water tank. Ensure that the vertical section of the bracket above the heat exchanger is flush with the side of the tank before you drive in the screws.
7. While holding the bracket and the SolVelox firmly against the tank, drive two #10-16 x 3/4” self drilling screws into the lower section of the bracket just below the heat exchanger and two screws just above the heat exchanger. It is critical that you hold the bracket and SolVelox firmly against the tank at this point otherwise it will be loose when you stand the tank upright. Seek assistance to make sure you get the product snug on the tank.
8. Connect a brass tee to the cold water inlet to

Figure 12 - SolVelox Piping

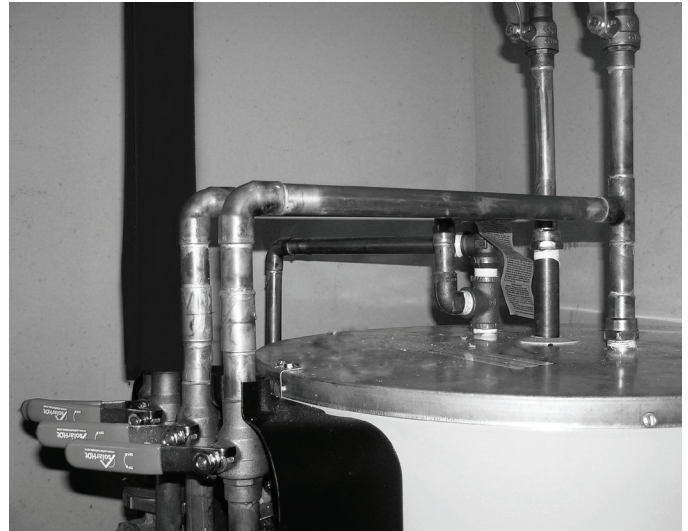

- the tank, drive four #10-16 x 3/4” self drilling screws into the bracket with two just above and two just below the heat exchanger. **See Figure 12.**
9. Using 1/2” copper pipe or 1/2” flexible stainless steel pipe, join ball valve D of the SolVelox assembly with a tee connected to the cold inlet. This is the cold water input to the SolVelox. **See Figure 13.**
 10. Using 1/2” pipe and fittings or 1/2” MxF flexible stainless steel pipe, connect the hot water inlet (where you previously installed the solar dip tube) to ball valve C on the SolVelox. This is the hot water return to storage.
 11. Using the flexible stainless steel tubing, attach the expansion tank to the expansion tank port at the lowest point on the left, below the collector loop pump. Mount the expansion tank to the wall or to the storage tank. **See Figure 14.**

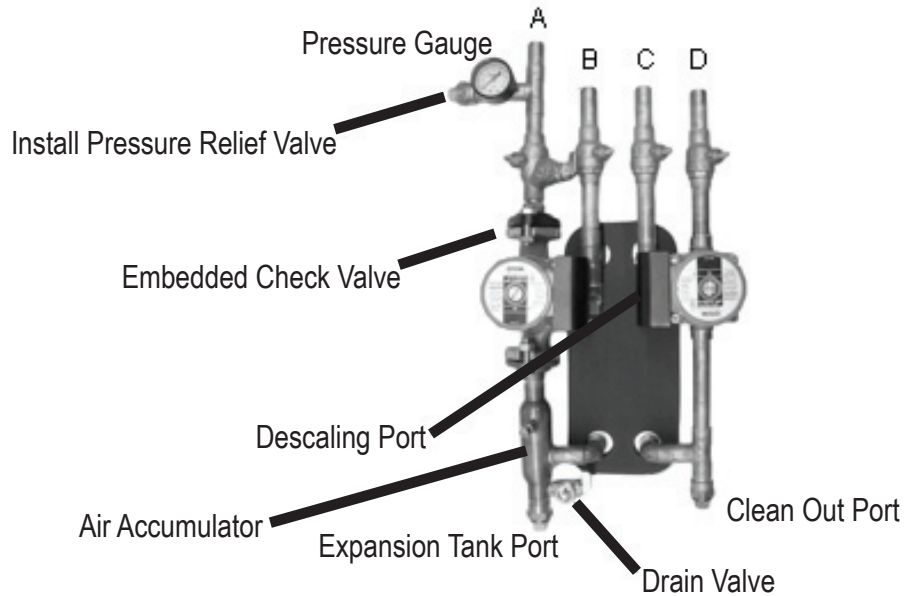
Figure 13 - Glycol Piping Diagram

12. Attach a pressure relief valve to the port found at the left side of the pressure gauge. The pressure relief should point towards the ground.
13. The ports A and B on the left are for the collector loop. The pipe coming from the top of the collectors carries the hot antifreeze solution and should be attached to port B. The pipe leading to the collector attaches to port A directly above the pressure gauge. Connect the collector return to the SolVelox via the second ball valve from the left.

Figure 14 - Expansion Tank**Installing the Differential Control****⚠ WARNING Burn and Scald Hazard.**

Excessive water temperatures could cause explosion, burns, scalding, pressure relief flooding and fitting leaks. Carefully follow the outlined procedures for temperature sensor installation to ensure accurate water temperature sensing and effective control operation.

Your glycol system is automated by the differential control located on the face of the SolVelox cover, as shown in **Figure 15**.

When installing the SolVelox pump package, consult the appliance manufacturer's instructions for additional information on wiring, installing the three sensors, and programming the control. **See also Figure 16.**

Figure 15 - SolVelox Wiring

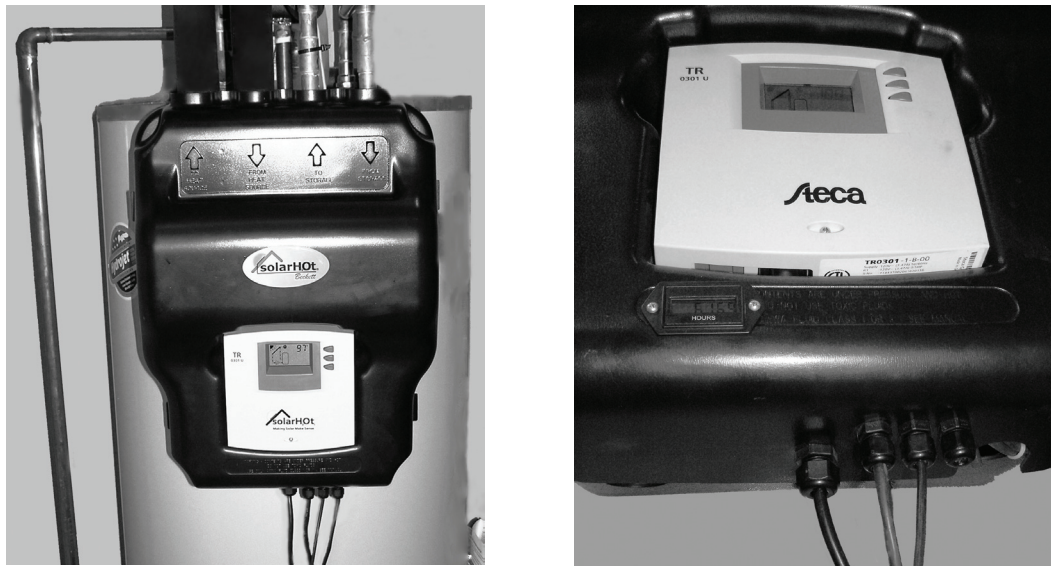
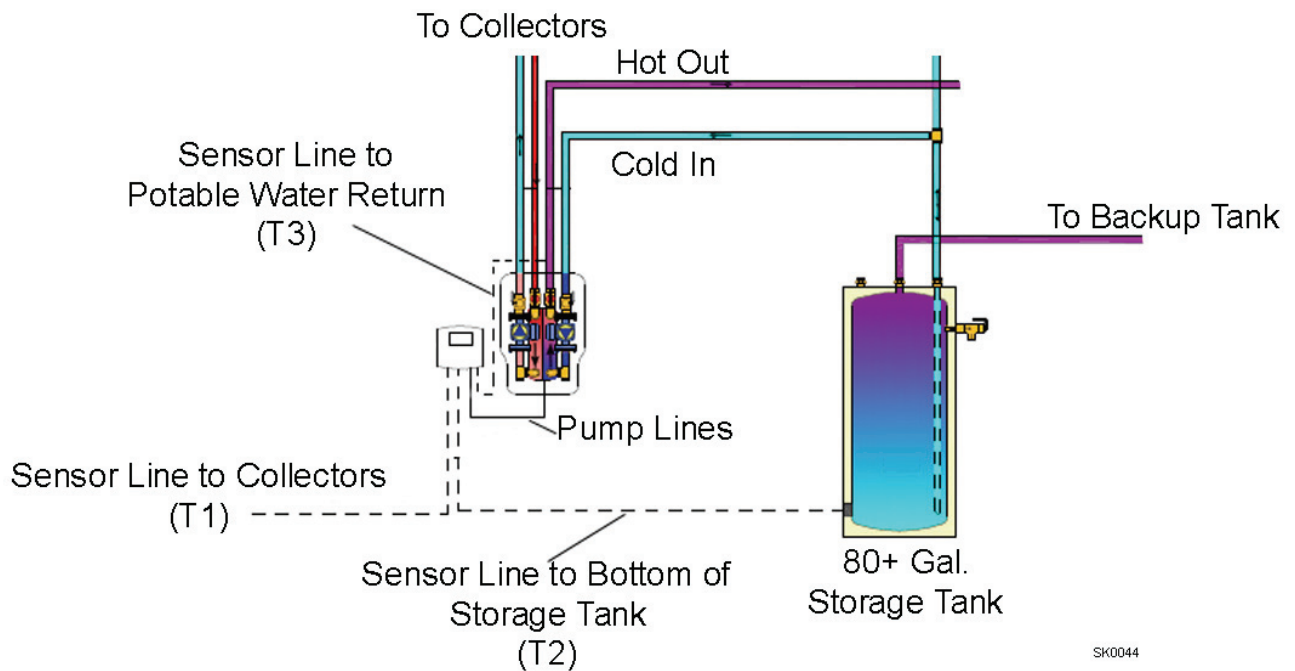

Figure 16 - SolVelox Wiring Diagram



SK0044

1. For the first sensor, 50' of 18 gauge sensor wire is included to reach the panel collectors. If you require more wire for your system design, use UV stable (black) 18 gauge sensor wire. This sensor is denoted by T1 on the Steca display.
2. The lower tank sensor is approximately 5' long. Remove the lower access panel shown in **Figure 17** and place the sensor firmly against the interior tank surface. The heavy insulation should hold it securely

Figure 17 - Lower Tank Sensor



in place. While the panel is open, turn the bottom heating element to its lowest set point. This sensor is denoted by T2 on the Steca display.

3. The short sensor wire is to be installed on the pipe returning to the backup water heater (potable water return) from the heat exchanger by using a stainless steel screw clamp (**Figure 13, Port C**). It should be placed on the pipe as far from the control as possible. Insulate over the sensor. This sensor is denoted by T3 on the Steca display.

Check Collector Loop for Leaks

1. Before system has been charged, open all shut-off valves on collector loop.
2. Attach a female to male adapter to the drain valve on the bottom left of the SolVelox.
3. Open drain valve and attach gas test block with pressure gauge.
4. Apply 60 psi pressure for 15 minutes. Any drop in pressure during that time indicates a leak.
5. Find the source of the leak and repair it. Repeat this procedure until the loop holds pressure.



Charging the System

1. Connect the outlet of a 1HP pump via a hose to the fill valve, located below the pressure gauge on port A. **Refer to Figure 13.**
2. Open fill valve.
3. Open the drain valve, located on the bottom left corner of the SolVelox (below the pump which leads to port A).
4. Connect drain valve to a bucket.
5. Fill the bucket with the appropriate mixture of propylene glycol and water. (see manufacturer's recommendation on the percentage of propylene glycol necessary for freeze protection in your area. We recommend Noble NoBurst.)
6. Run pump. Initially air will vent out of the boiler drain, then a mixture of coolant and air will follow. This process may take 10-30 minutes.
7. Continue running the pump until you do not see air bubbles in the coolant.
8. Turn off pump. Let the system sit for 2 minutes.
9. Discharge any air caught in the air trap using the schrader valve located below the collector pump.
10. Repeat previous steps until no air is discharged.
11. Close drain valve.
12. Continue charging until it reaches the necessary pressure for the system's configuration. The system requires 15 psi plus 1 psi per 2.3 vertical feet to the top of the collector.
13. Close the fill valve.
14. Turn off and disconnect charging pump.

Starting the System

1. Confirm that all shut-off valves are fully open.
2. Turn on system and let it run for 5 minutes.
3. Double-check every component and all pipe runs and fittings for leaks.
4. Adjust upper element of the water heat to a maximum of 120° F for back up heat.
5. Set the high limit on the control to no more than 185° F. Refer to Steca owner's manual.

Check System Operation

Let the system run for 15 minutes on a sunny day, preferably around noon. Three temperatures will show on the control: the collector outlet temperature, the bottom of the tank temperature, and the temperature of the water returning to the tank. Typically you should see the temperature at the bottom of the tank vary from 60-80° F (city water temperature) to 185° (high limit set on the control) The water at the top of the tank will be typically higher than the water at the bottom, but should not exceed the high limit set on the control. The Temperature and Pressure Relief Valve on the storage tank is set to 210° F.

The system will automatically turn on the pumps when the collector temperature is 16° higher than the water at the bottom of the tank. It will shut off the system when the temperature differential is 8° F. Collector temperatures may rise well above 200° F, but the system will not run beyond the high limit set on the control.

A system correctly installed will show the water returning to the tank to be at least 3-10° F warmer than the water at the bottom of the tank.

Operation

Figure 18 - Differential Control

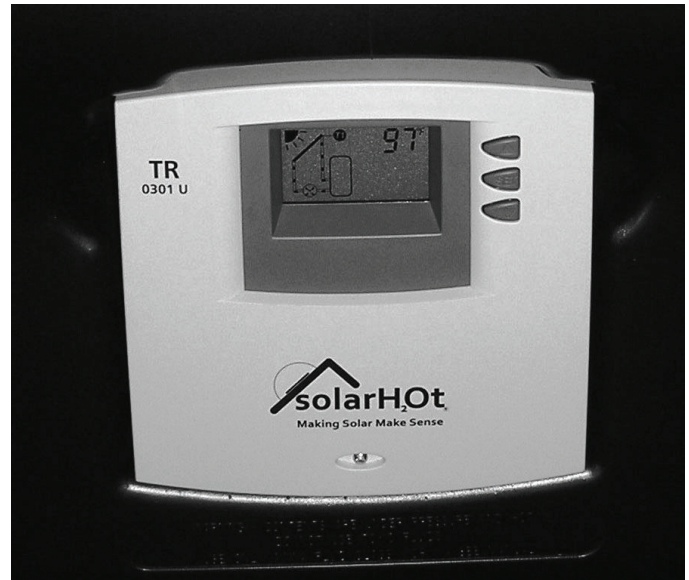

Please refer to the differential control owner's manual for system operation or adjustments.

Vacation Settings

If the system is not to be used for any extended period of time, the differential control should be set to HOLIDAY function:

1. Open the menu settings by pressing the "SET" button for approximately two seconds.
2. Press the "DOWN" button until the holiday symbol (umbrella) flashes.
3. Press the "SET" button for approximately two seconds, until the small tick on the holiday symbol appears.

To Resume Operations:

1. Open the menu settings by pressing the "SET" button for approximately two seconds.
2. Press the "DOWN" button until the holiday symbol (umbrella) flashes.
3. Press the "SET" button for approximately 2 seconds until the small tick on the holiday symbol disappears.
4. See the Steca control manual for more details about the HOLIDAY function.

Emergency Shut Off

1. If there is a leak or other issue requiring the collector loop to be drained, turn the system off by setting the switch on the left side of the differential control to the “OFF” position.

WARNING Burn Hazard.

Exercise extreme caution when draining, as the heat transfer fluid may be dangerously hot.

2. Attach a hose to the drain valve on the lower left of the SolVelox. **See Figure 13.**
3. Open the drain valve.

Warning! DO NOT dispose of the heat transfer fluid on the ground or in the water system. Collect it in a container which can be sealed and dispose of it according to the manufacturer’s directions.

Maintenance

Your solar water system requires very little by way of maintenance, but a few regular system checks can extend the life of your system well beyond 20 years.

Freeze Protection

This system is designed to protect itself from freeze damage to temperatures as low as -30°F as long as the heat transfer fluid in the collectors is at least 40% GRAS propylene glycol. Freeze tolerance limits are based upon an assumed set of environmental conditions. In the event of extreme or prolonged cold weather, protect your system by shutting it down and draining the collector loop as described in the “Vacation Settings” and “Emergency Shut- Off” sections.

Clear Sediment from Strainer

1. Turn off your solar water system with the switch on the side of the differential control and disconnect the power to the SolVelox

by unplugging it from the wall outlet.

WARNING Burn Hazard.

Exercise extreme caution when draining, as the heat transfer fluid may be dangerously hot.

2. Close the two shut-off flanges on the right side of the SolVelox. **See Figure 13, ports C & D.**
3. Open the clean out port. **See Figure 13.**
4. Remove any sediment buildup from the clean out port.
5. Close and tighten clean out port.
6. Return shut-off flanges to the open position and reconnect the power to the SolVelox.

Descaling the Heat Exchanger

1. Turn off your solar water system with the switch on the side of the solar differential control and disconnect the power to the SolVelox by unplugging it from the wall outlet.
2. Close the two shut-off valves on the right side of the SolVelox. **See Figure 13, ports C & D.**
3. Unscrew the plugs to open the descaling and clean out ports shown in **Figure 13.**
4. Remove any sediment buildup from the clean out port.
5. Flush the heat exchanger with a weak solution of white vinegar and water.
6. Close and tighten descaling and clean out ports.
7. Return shut-off flanges to the open position and reconnect the power to the SolVelox.

Change Heat Transfer Fluid

The heat exchange fluid contains buffers which keep the pH of the solution neutral. Heat and time will degrade these buffers, so it is important

that you drain the fluid and recharge the system every 3-5 years.

To drain the system:

1. Turn the system off by setting the switch on the left side of the differential control to the "OFF" position.

Burn Hazard.



WARNING *Exercise extreme caution while draining, as the heat transfer fluid may be dangerously hot.*

2. Attach a hose to the drain valve on the lower left side of the SolVelox. **See Figure 13.**
3. Open the drain valve. Dispose of used heat transfer fluid according to manufacturer's directions.

Pumps

The circulation pumps have a life expectancy of 5-10 years. If a pump should require servicing or replacement:

1. Turn off the system with the switch on the side of the differential control.
2. Close all the ball valves at the top of the SolVelox. Leave the system off for several hours until the pumps are completely cooled to room temperature.
3. Solar pumps are flanged so they can be easily removed by loosening the flange's nuts and bolts. Potable loop pumps use bolts and must be unscrewed.

Service

To obtain service for your SolVelox™, notify the dealer who installed or sold the SolVelox™. In notifying your dealer, provide identification of

your SolVelox™, date of purchase (with proof), and the nature of the defect. Ship the SolVelox™ complete in the assembled condition. Use adequate packaging to prevent damage to the pump during shipment.

To obtain the location of the nearest authorized SOLARHOT service and/or distribution facility, call (919) 439-2387 or write to:

SOLARHOT Ltd.

2800 Perimeter Park Dr. Suite A
Morrisville, NC 27560

or on the web at:

<http://www.solarhotusa.com>

email: sales@solarhotusa.com

Warranty Information

Limited Two Year
MANUFACTURER'S WARRANTY
For SolVelox Glycol System

SolarH²Ot Limited warrants to buyer for a period of twenty-four (24) months from the date of sale that the equipment at the time of shipment will be free from defects of design, material, and workmanship.

- If any defects or malperformance occur during the warranty period, SOLARHOT's sole obligation shall be limited to alteration, repair, or replacement at SOLARHOT's expense, F.O.B. Factory, of parts or equipment, which upon return to SOLARHOT and upon SOLARHOT's examination prove to be defective.
- Equipment and accessories not manufactured by SOLARHOT are warranted only to the extent of and by the original manufacturers' warranty.
- SOLARHOT shall not be liable for damage or wear to equipment caused by abnormal conditions, acts of God, failure to properly prime or to operate equipment without flow or caused by corrosives, abrasives or foreign objects.

THE FOREGOING WARRANTY IS EXCLUSIVE AND IN LIEU OF ALL OTHER WARRANTIES, WHETHER EXPRESSED OR IMPLIED, INCLUDING ANY WARRANTY OF MERCHANTABILITY OR FITNESS FOR ANY PARTICULAR PURPOSE.

IN NO EVENT SHALL SOLARHOT BE LIABLE FOR CONSEQUENTIAL OR INCIDENTAL DAMAGES.

Limited Ten Year
MANUFACTURER'S WARRANTY
For SolarHot Platinum Collectors

SolarHot Limited warrants to buyer for a period of ten (10) years from the date of sale that the equipment at the time of shipment will be free from defects of design, material and workmanship.

- If any defects occur during the warranty period, SOLARHOT's sole obligation shall be limited to alteration, repair or replacement at SOLARHOT's expense, F.O.B. Factory, of parts or equipment, which upon return to SOLARHOT and upon SOLARHOT's examination prove to be defective.
- Equipment and accessories not manufactured by SOLARHOT are warranted only to the extent of and by the original manufacturers' warranty.
- SOLARHOT shall not be liable for damage or wear to equipment caused by abnormal conditions, acts of God, failure to properly prime or to operate equipment without flow or caused by corrosives, abrasives or foreign objects.

Please note that the warranty does not apply to conditions or damage caused by:

1. A failed component or part that is not a part of the SOLARHOT collector.
2. Freezing conditions.
3. Misuse, abuse, neglect, accident, or alteration.
4. Cosmetic discoloration of the frame-wall, absorber plate, or glazing over time.
5. Glass breakage.
6. The introduction of harmful chemicals, caustic fluids, or liquids deleterious to copper tubing, including improperly applied or maintained heat transfer fluids and chlorinated water. The use of SOLARHOT collectors for pool or spa heating is not covered by this warranty unless the pool or spa water is isolated from the collector through the use of a heat exchanger.
7. Heat transfer fluids other than distilled water or propylene glycol are used.
8. Propylene glycol pH levels exceeding 10 or falling below 8.
9. Stagnation in excess of 30 days.
10. Excessive pressure.
11. Excessive flow rates.
12. Improper plumbing configurations.
13. Clouding or condensation naturally resulting from temporary intrusions of moisture into the collector.
14. Acts of God.
15. Installation methods, including mounting, that do not conform to relevant national, state, or local codes and ordinances, good industry practices, or current applicable SOLARHOT manuals, diagrams, or installation instructions.

THE FOREGOING WARRANTY IS EXCLUSIVE AND IN LIEU OF ALL OTHER WARRANTIES, WHETHER EXPRESSED OR IMPLIED, INCLUDING ANY WARRANTY OF MERCHANTABILITY OR FITNESS FOR ANY PARTICULAR PURPOSE.

IN NO EVENT SHALL SOLARHOT BE LIABLE FOR CONSEQUENTIAL OR INCIDENTAL DAMAGES.

Field labor to repair or replace any defective SOLARHOT product is reimbursable as follows:

Year 1: \$100 per collector

Year 2-5: \$75 per collector

Year 6-10: \$50 per collector

After one (1) year of warranty, freight and shipping costs are the responsibility of the owner.

GLYCOL SYSTEM



SOLARHOT Ltd.

2800 Perimeter Park Dr. Suite A · Morrisville, NC 27560 · Phone: 919.439.9061

Fax 919.573.0791 · Email: sales@solarhotusa.com

www.solarhotusa.com